

## 70L WATER SLIMLINE Underbody

**TOLERANCES**  
 NOTE: UNLESS NOTED OTHERWISE,  
 PLEASE ALLOW DIMENSIONAL TOLERANCES  
 DUE TO FABRICATION PROCESS AND  
 POLYETHYLENE THERMAL EXPANSION  
 DIMENSIONS <200mm - ALLOW ±3mm  
 DIMENSIONS 200 - 1000mm - ALLOW ± 5mm  
 DIMENSIONS >1000mm - ALLOW ± 10mm

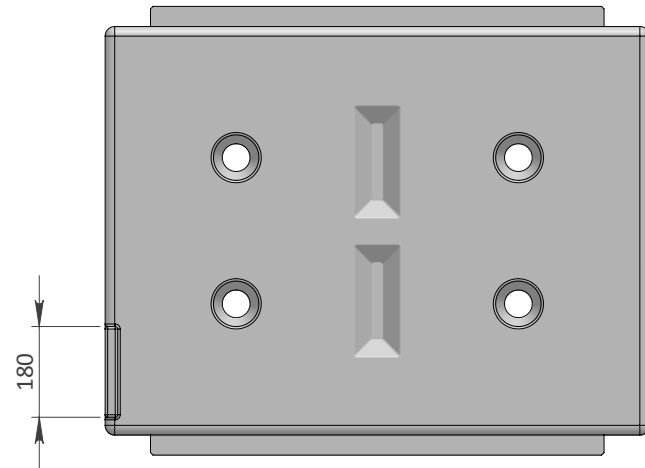

TOP VIEW

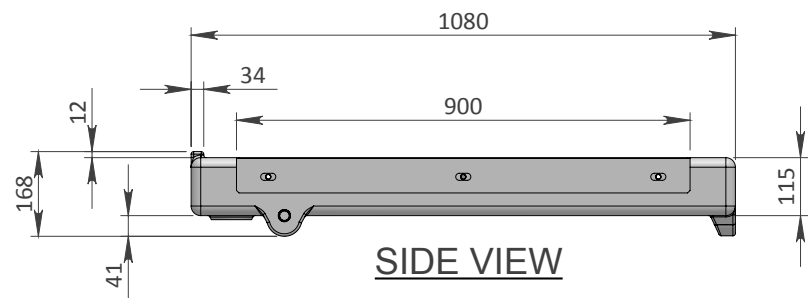

SIDE VIEW

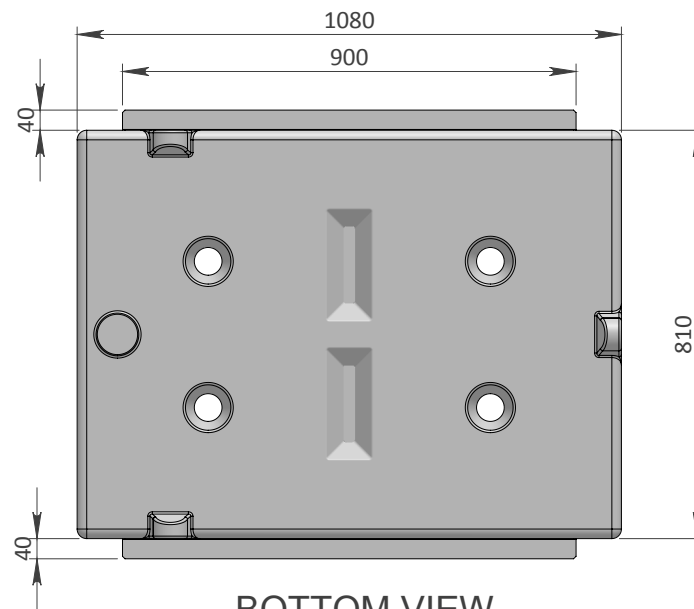

BOTTOM VIEW

MARK	PART	MATERIAL	QTY	PART CODE	DRAWING REF.
1	70L WATER SLIMLINE TANK	FOOD GRADE POLYETHYLENE	1	BOX405.8000	
2	70L MOUNTING BKT.	1.6mm GALVANISED SHEETMETAL	2	PARBKT0045	PARBKT0045
3	BRACKET BOLT	M10 x 25 HEX HD. ZP.	6	PARSCR0305	
4	SPRING WASHER	M10 x3.5x2.2 ZP.	6	PARSCR0504	
5	FLAT WASHER	M10 25 O.D x 2mm ZP.	6	PARSCR0503	
6	1" BRASS INSERT	BRASS	1	PARSCR4025	
8	1/2" POLY PLUG	POLY PLUG , HEX W/O-RING	2	PARPLF1721	
9	10mm THREADED INSERTS	BRASS	6	PARSCR0003	
10	1/2" THREADED INSERTS	BRASS	4	PARSCR3105	

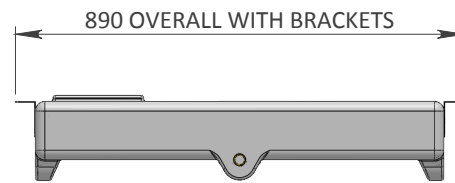

END VIEW

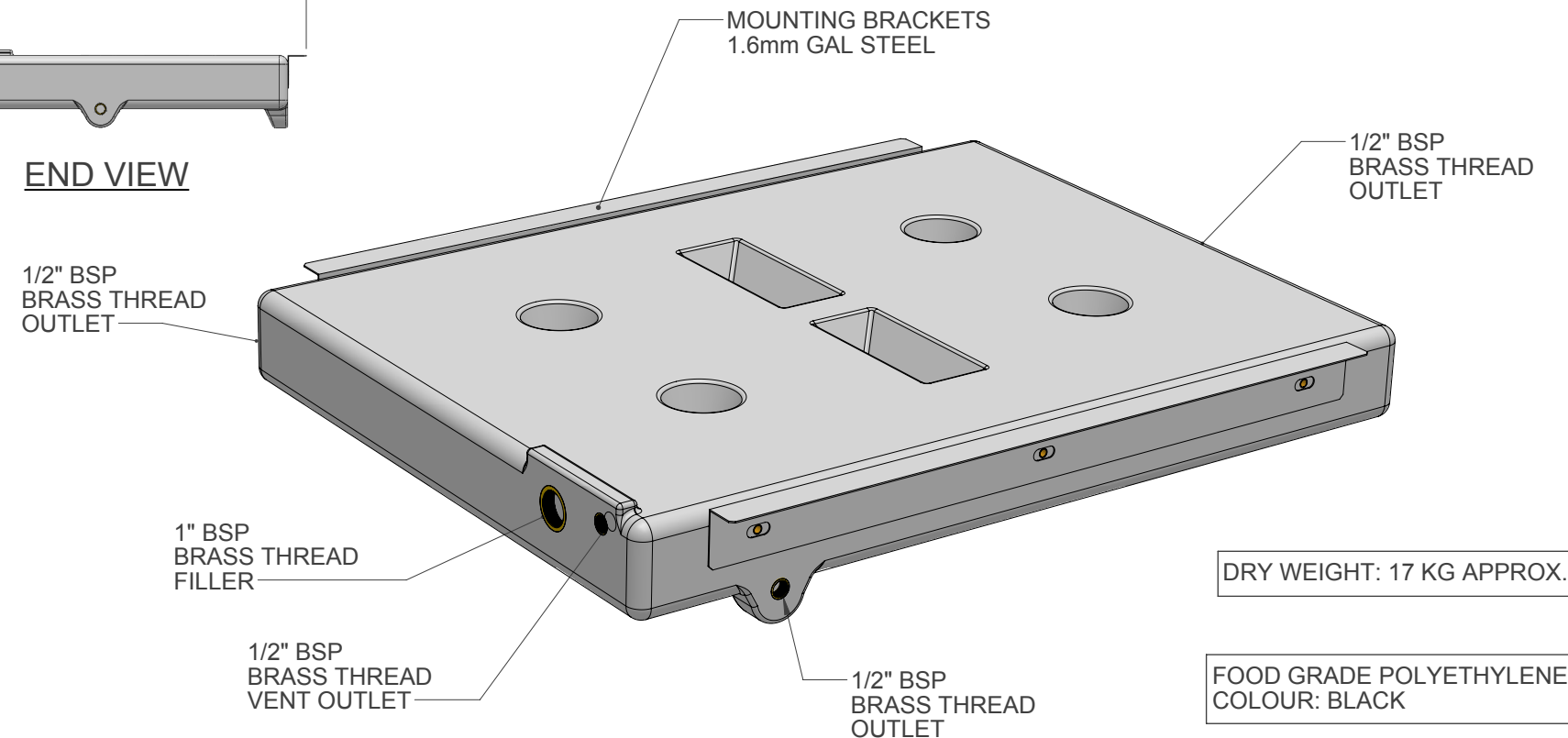

DRY WEIGHT: 17 KG APPROX.

FOOD GRADE POLYETHYLENE  
COLOUR: BLACK

Polyethylene material meets:  
 AS2070 - Plastic materials for food contact use  
 AS/NZS4020 - Testing of products for use in contact with drinking water

REV	DATE	REVISION DESCRIPTION	DRAWN	CHKD	LEAD ENG
A	16.10.18	AS BUILT	DH		