

VS 65 L CANOPY TANK OPERATION MANUAL

Installation Options:

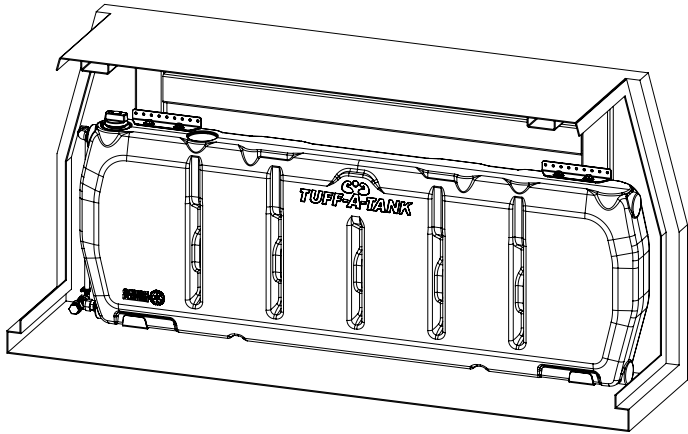

Option A - Bracket Kit:
Bracket Kits are Available for Purchase.
Refer to Bracket Kit Installation Instructions.

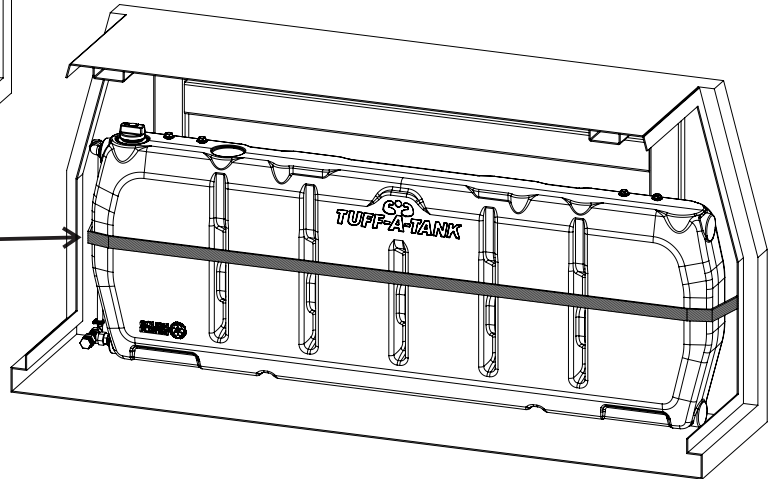

Option B - Ratchet Strap:

Use suitably sized strap to secure Tank.
Run Strap through moulded channel for best fit.
Ensure strap is tight prior to driving.

Important ⚠

DO NOT USE BUNGEE CORDS

The above 2 Option are the Recommended methods of installation by the Manufacturer.
Other methods are at the discretion of the customer, Improper Installation that results in damage to the tank will void Warranty.

Usage Guidelines:

Water Tank:

- Rinse Tank Prior to First Use
- Not Suitable for Liquids other than Water
- Use to store water, Secured to the vehicle with a transfer method, such as Gravity, Submersible or Diaphragm Pump.

Diesel Tank:

- FOR DIESEL ONLY
- Not Suitable for Petrol
- Do Not Over Fill, Room for Expansion Is Required for Diesel Tanks, as shown right, the Max Fill Level is when the Diesel enters the top elbow of the sight tube.
- Not for use as Vehicle Primary fuel Tank.

DIESEL MAX FILL LINE

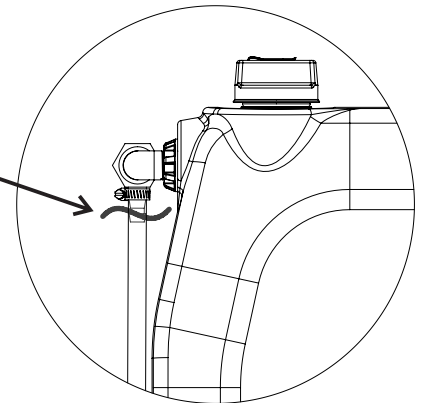

Important ⚠

Diesel Tank Usage Options:

Usage Option 1 – Storage Tank, Secured to the vehicle to store and transport diesel completely independent of the vehicle fuel system. (No certification required.)

Usage Option 2 – Portable Transfer Tank, Secured to the vehicle with a Diesel transfer method, such as Gravity or Submersible Pump. Not Connected to Onboard fuel system, transferring via Diesel Hose kit. (No certification required.)

Usage Option 3 – Auxiliary Tank, Secured to the vehicle and permanently installed into the vehicle fuel system, as a Secondary Tank, cannot be used as a Primary Fuel Tank. **Certification is Required** (Light Vehicle LM1 Fuel system modification 'Blue Plate')

Contact the Department of Transport & Main Roads (QLD) Ph: 13 22 80

(SEE GOUGH PLASTICS DIESEL VEHICLE SLIMLINE TANKS USAGE GUIDELINES FOR MORE INFO.)

PUMP USAGE GUIDELINES

The Following Applies to Tanks that were Purchased with a Pump Installed:

RECOMMENDED TO HAVE PROFESSIONAL AUTO ELECTRICIAN WIRE PUMPS TO VEHICLE AND INSTALL WITH THE RELEVANT FUSE AS SHOWN BELOW;

- DIAPHRAGM PUMP (SFDP1-010-040-21) = 12V DC, 1.6 Amp, 8.0 Amp Fuse
- WATER SUBMERSIBLE PUMP (SFSP1-G200-03B) = 12V DC, 2.5 Amp, 4.0 Amp Fuse
- DIESEL SUBMERSIBLE PUMP (SFSP1-G280-02A) = 12V DC, 4.5 Amp, 7.5 Amp Fuse

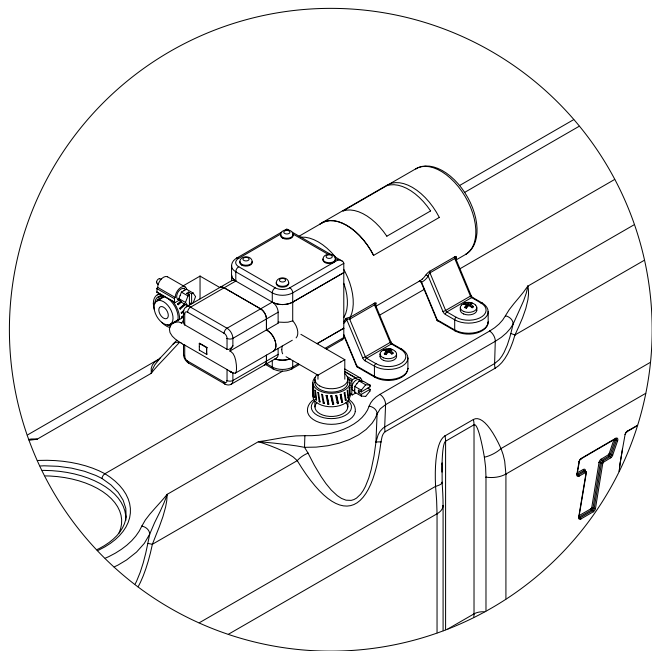

Important

Diaphragm Pump:

For Clean Water Only, any particles could damage the pump. Recommended to turn off pump when not in use. Do Not run pump dry.

*This pump should be wired on it's own dedicated circuit. the circuit should be protected with a Fuse in the positive lead. An **8.0 Amp** fuse is required.*

Recommended to loosen filler cap while transferring to improve tank venting.

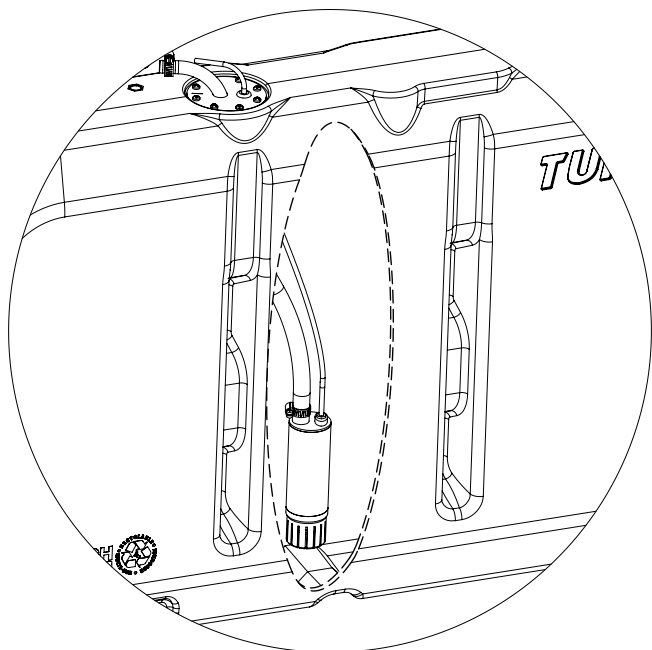

Important

Submersible Pump:

Do Not run pump dry. Do Not run pump with hose valve shut off. Recommended to loosen filler cap while transferring to improve tank venting.

The above applies to both Water and Diesel Submersibles.

WATER:

For Clean Water Only, any particles could damage the pump Switch pump off immediately after finishing to transfer to avoid pump damage. Do Not Pump Water above 60°C or below 0°C

*This pump should be wired on it's own dedicated circuit. the circuit should be protected with a Fuse in the positive lead. An **4.0 Amp** fuse is required.*

DIESEL:

Do Not Pump Diesel above 50°C Do Not use to Pump Petrol or any liquid with ignition point below 37°C.

*This pump should be wired on it's own dedicated circuit. the circuit should be protected with a Fuse in the positive lead. An **7.5 Amp** fuse is required.*

VS 65 L CANOPY TANK BRACKET KIT INSTALLATION

WARNING

DO NOT USE RATTLE GUNS OR POWER TOOLS TO TIGHTEN BOLTS TO THE TANK, OVER TIGHTENING MAY RESULT IN DAMAGE TO BRASS FITTING AND TANK - VOIDING WARRANTY.

