

640L WATER CARTAGE TANK

TOLERANCES
 NOTE: UNLESS NOTED OTHERWISE,
 PLEASE ALLOW DIMENSIONAL TOLERANCES
 DUE TO FABRICATION PROCESS AND
 POLYETHYLENE THERMAL EXPANSION
 DIMENSIONS <200mm - ALLOW ±3mm
 DIMENSIONS 200 - 1000mm - ALLOW ± 5mm
 DIMENSIONS >1000mm - ALLOW ± 10mm

MARK	PART	MATERIAL	PART CODE	DRAWING REF.
1	640L WATER CARTAGE TANK	BLUE WATER GRADE POLYETHYLENE	FFAR500.0000	
2	255mm HINGED LID - VENTED	BLACK POLYPROPYLENE	PARTAC.0200	

DRY WEIGHT: 35 KG APPROX.

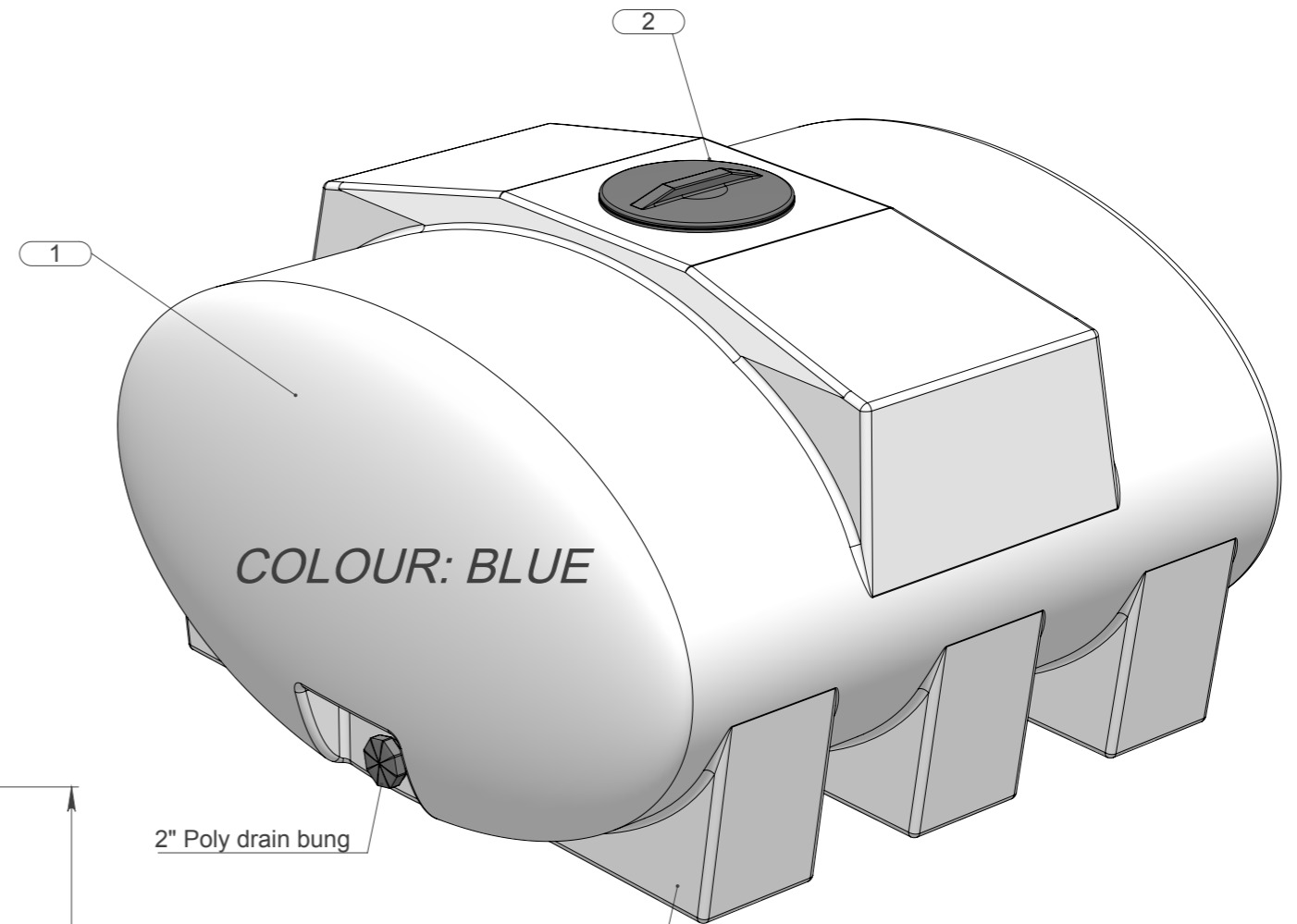
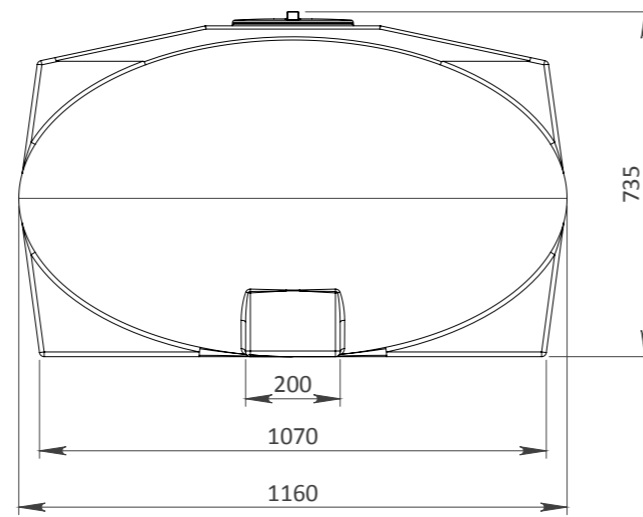
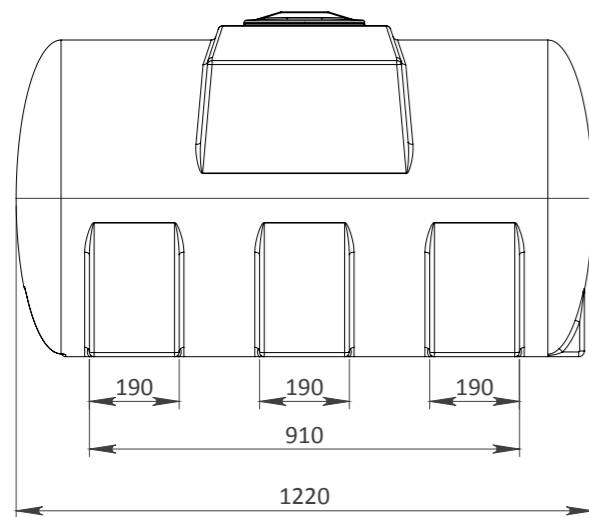
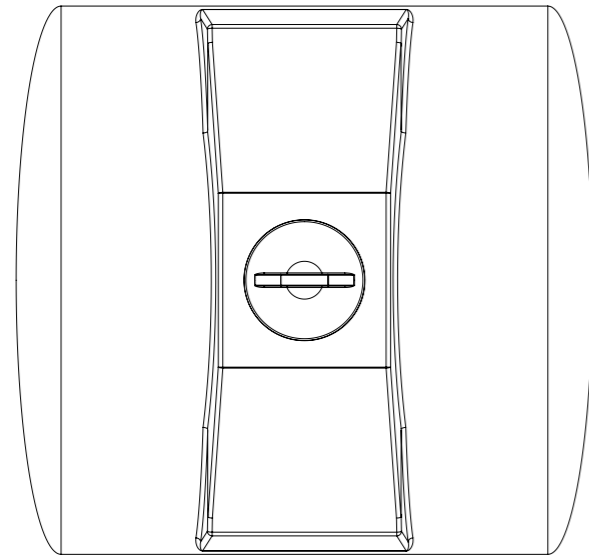

Note:
 There are no hold-down points moulded into this tank
 Tank can be fixed down with suitable ratchet straps\ metal straps.

REV	DATE	REVISION DESCRIPTION	DRAWN	CHKD	LEAD ENG
A	30.10.18	AS BUILT	DH	JG	