

# VS 55L WELLBODY TANK SUBMERSIBLE WATER (INC. SUBMERSIBLE PUMP FITTED INSIDE TANK)

**TOLERANCES**  
UNLESS NOTED OTHERWISE  
PLEASE ALLOW BELOW TOLERANCES  
DIMENSIONS <200mm - ALLOW ± 5 mm  
DIMENSIONS 200 - 1000mm - ALLOW ± 10 mm  
DIMENSIONS >1000mm - ALLOW ± 15 mm

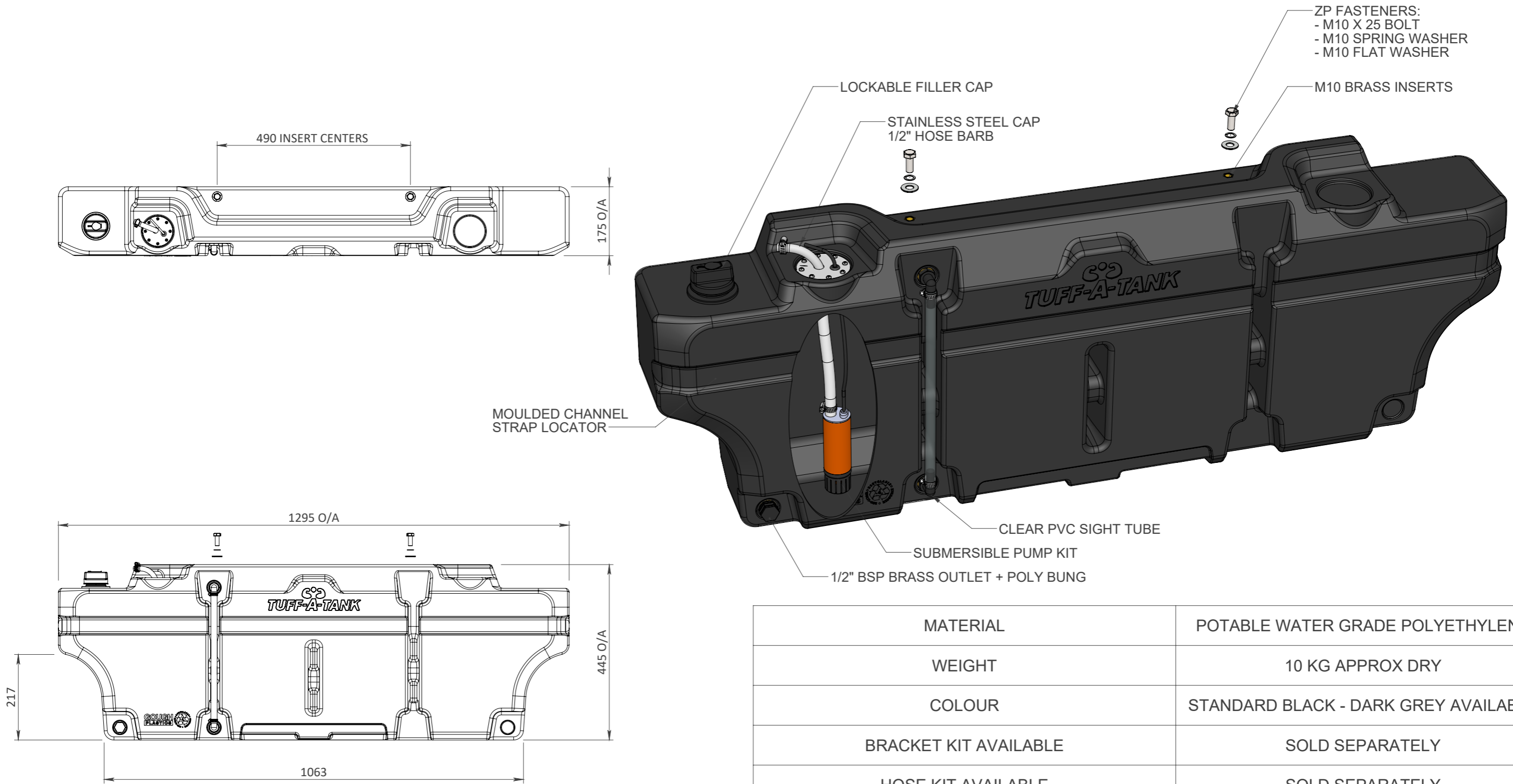

MATERIAL	POTABLE WATER GRADE POLYETHYLENE
WEIGHT	10 KG APPROX DRY
COLOUR	STANDARD BLACK - DARK GREY AVAILABLE
BRACKET KIT AVAILABLE	SOLD SEPARATELY
HOSE KIT AVAILABLE	SOLD SEPARATELY
HIGH FLOW LOW PRESSURE SUBMERSIBLE PUMP	12 V - 17 LPM

**RINSE TANK PRIOR TO USE**

A	23/09/2021	SALES DRAWING	MC	DH		 A.C.N. 010 028 547 Gough Industries Pty. Ltd. 833 Ingham Road Bohle, Townsville P.O. Box 7570, Garbutt BC, Qld. 4814. Telephone 07 47747606 www.gough.com.au	CLIENT LOGO.	VS - 55 L Wellbody Tank Submersible WATER Sales		REVISION
							SCALE	GOUGH PLASTICS DRAWING No.		
							NTS	A3	<b>FBOX408.1005.3</b>	<b>A</b>
REV	DATE	REVISION DESCRIPTION	DRAWN	CHKD.	ENG.	Dimensions are in millimetres (mm) unless noted.	SOLDWORKS: S:\Solidworks\Domestic\Slimlines\Vertical Slimlines\Wellbody\VS - 55 L Wellbody Tank Assem			
							PDF. FILE PATH: S:\Products\Domestic\Marketing Domestic\VS Tanks			