

# VS 55L WELLBODY TANK DIAPHRAGM WATER (INC. DIAPHRAGM PUMP FITTED TO TOP OF TANK)

**TOLERANCES**  
UNLESS NOTED OTHERWISE  
PLEASE ALLOW BELOW TOLERANCES  
DIMENSIONS <200mm - ALLOW ± 5 mm  
DIMENSIONS 200 - 1000mm - ALLOW ± 10 mm  
DIMENSIONS >1000mm - ALLOW ± 15 mm

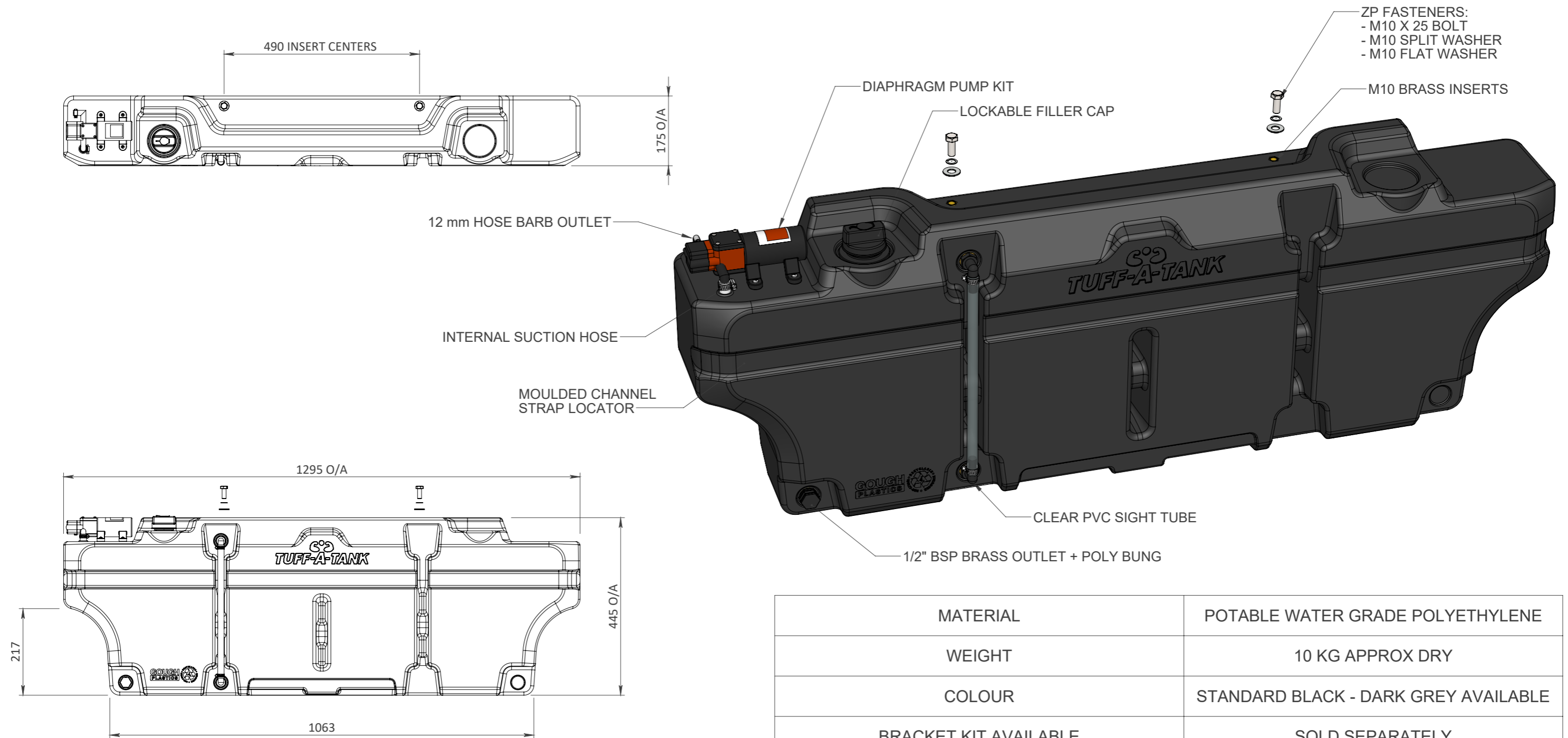

MATERIAL	POTABLE WATER GRADE POLYETHYLENE
WEIGHT	10 KG APPROX DRY
COLOUR	STANDARD BLACK - DARK GREY AVAILABLE
BRACKET KIT AVAILABLE	SOLD SEPARATELY
HOSE KIT AVAILABLE	SOLD SEPARATELY
HIGH PRESSURE LOW FLOW DIAPHRAGM PUMP	12 V - 3.8 LPM - 40 PSI

**RINSE TANK PRIOR TO USE**

A	23/09/2021	SALES DRAWING	MC	DH	<p>A.C.N. 010 028 547 Gough Industries Pty. Ltd. 833 Ingham Road Bohle, Townsville P.O. Box 7570, Garbutt BC, Qld. 4814. Telephone 07 47747606 www.gough.com.au</p>	CLIENT LOGO.	VS - 55 L Wellbody Tank Diaphragm Sales		SCALE <b>NTS A3</b>	GOUGH PLASTICS DRAWING No.	<b>FBOX408.1005.4</b>	REVISION
REV	DATE	REVISION DESCRIPTION	DRAWN	CHKD.		ENG.	SOLDWORKS: S:\Solidworks\Domestic\Slimlines\Vertical Slimlines\Wellbody\VS - 55 L Wellbody Tank Assem			PDF. FILE PATH: S:\Products\Domestic\Marketing Domestic\VS Tanks		<b>A</b>

Dimensions are in millimetres (mm) unless noted.