

GOUGH PLASTICS

5,000L MOLASSES CARTAGE TANK

TOLERANCES
 NOTE: UNLESS NOTED OTHERWISE,
 PLEASE ALLOW DIMENSIONAL TOLERANCES
 DUE TO FABRICATION PROCESS AND
 POLYETHYLENE THERMAL EXPANSION
 DIMENSIONS <200mm - ALLOW ±3mm
 DIMENSIONS 200 - 1000mm - ALLOW ± 5mm
 DIMENSIONS >1000mm - ALLOW ± 10mm

MARK	PART	MATERIAL	PART CODE	DRAWING REF.
1	5,000L HD MOLASSES CARTAGE TANK	BLACK HD GRADE POLYETHYLENE	FFAR500.5051	
2	455mm HINGED LID - VENTED	BLACK POLYPROPYLENE	PARTAC.0203	
3	4" / 100mm STUB FLANGE & VALVE	GAL BACKING RING, CAST IRON VALVE	FTAN204.0030	

4"/100mm STUB FLANGE & VALVE KIT - FTAN204.0030	
4" PE STUB FLANGE	PARWEF0301
4" GAL BACKING RING	PARWEF0401
4" BUTTERFLY VALVE	PARTAC1091
4" GAL DRD FLANGE	PARTTAC1086
M16 x 110mm GAL BOLT (4) + NUT+2FW	PARMIM0040

DRY WEIGHT: 310 KG APPROX.

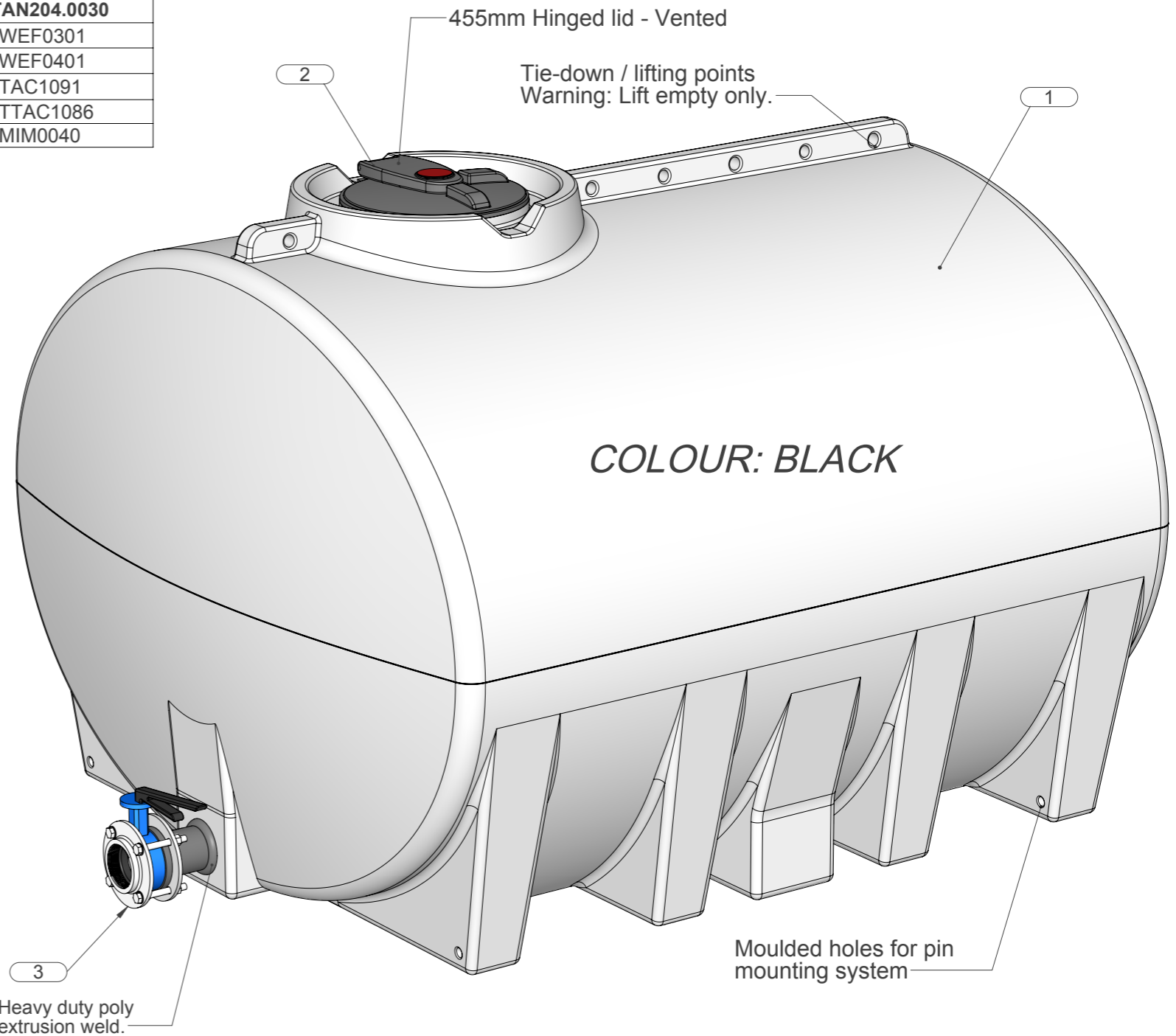
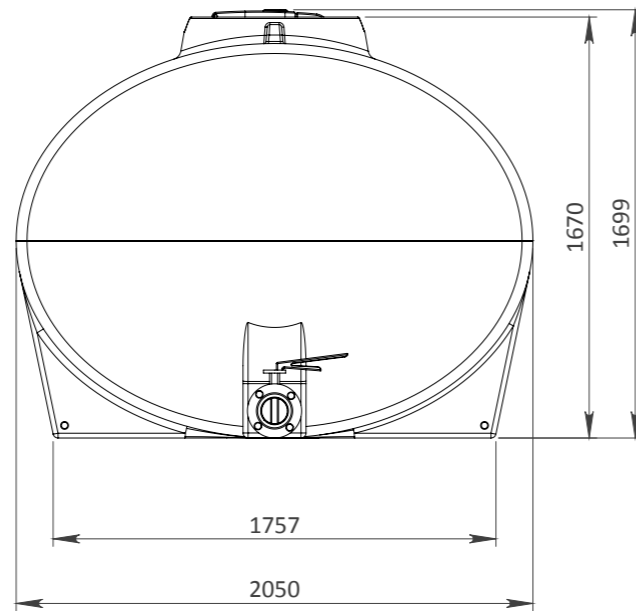
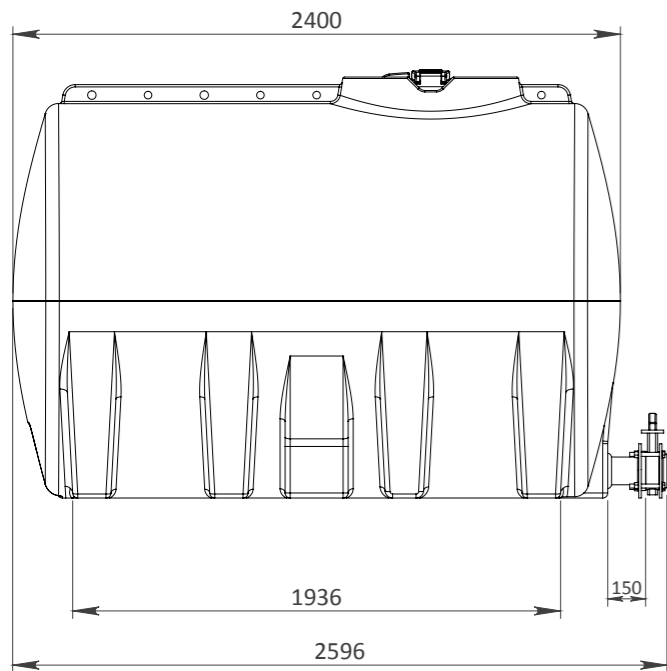
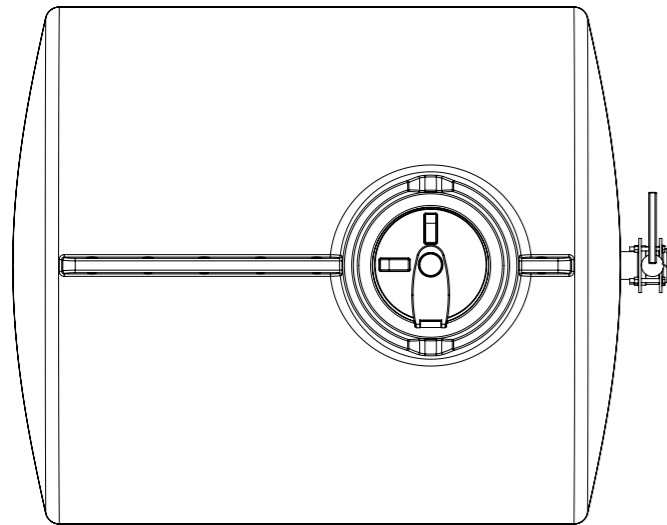

REV	DATE	REVISION DESCRIPTION	DRAWN	CHKD	LEAD ENG
A	17.10.18	AS BUILT	DH	JG	

GOUGH PLASTICS

A.C.N. 010 028 547
 Gough Industries Pty. Ltd.
 833 Ingham Road
 Bohle, Townsville
 P.O. Box 7570, Garbutt BC, Qld. 4814.
 Telephone 07 47747606
 Facsimile 07 47747608

CLIENT LOGO.

5,000L HD MOLASSES CARTAGE TANK

SCALE
 NTS

A3

Gough Plastics Drg. No.

RUR-MOLAS-5000

A

VP

S:\Products\Rural\Cartage tanks