

# 25L CHECKER PLATE UNDERBODY WATER TANK INSTALLATION INSTRUCTIONS

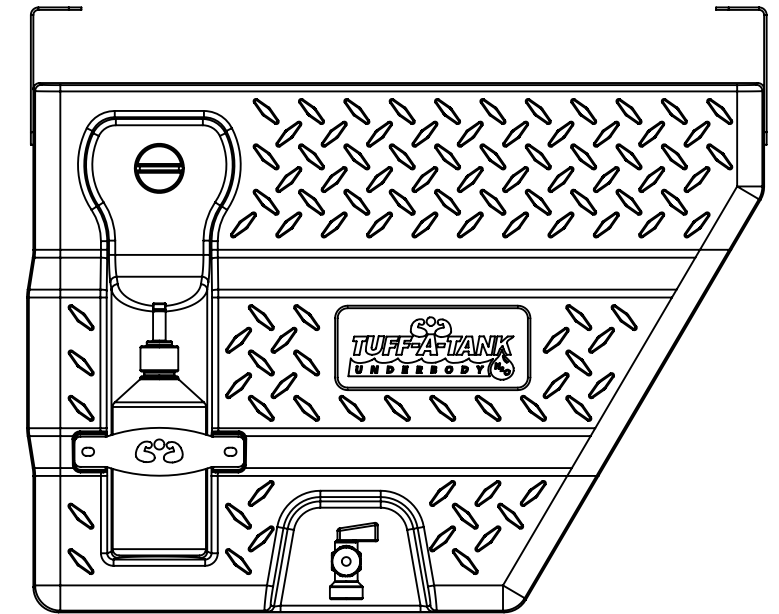

1. HOLD UP UNDERBODY WITH BRACKETS AND MARK HOLE LOCATIONS
2. DRILL  $\phi$  12 HOLES FOR BOLTS OR PILOT HOLES FOR SCREWS
3. REMOVE BRACKETS FROM UNDERBODY AND FIX TO TRAY WITH BOLTS OR SCREWS
4. LIFT TANK INTO PLACE AND FIX UNDERBODY TO 'L' BRACKETS WITH BOLTS AND SPRING WASHERS
5. BEND MUDGUARD BRACKET INTO PLACE AND FIX TO UNDERSIDE OF UNDERBODY WITH BOLT AND SPRING WASHER (WHERE APPLICABLE)
6. IF BOTTLE IS REQUIRED ON OPPOSITE SIDE, SIMPLY UNSCREW BOTTLE PLATE AND FIT TO OTHER SIDE.

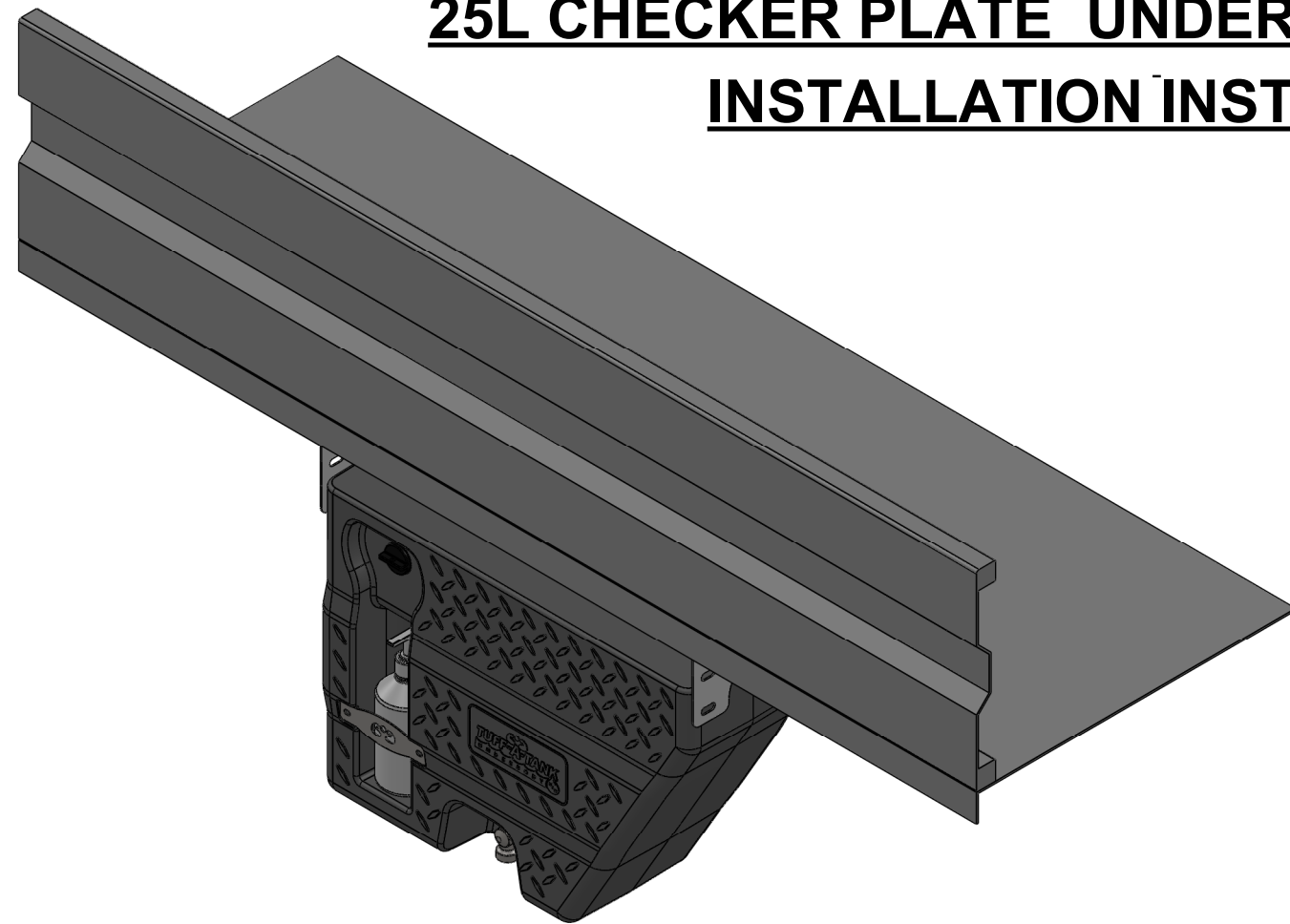
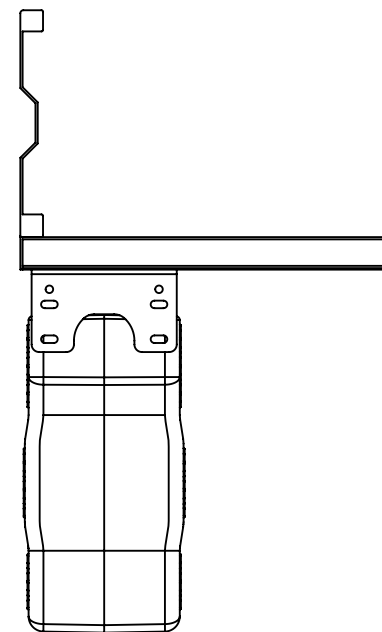
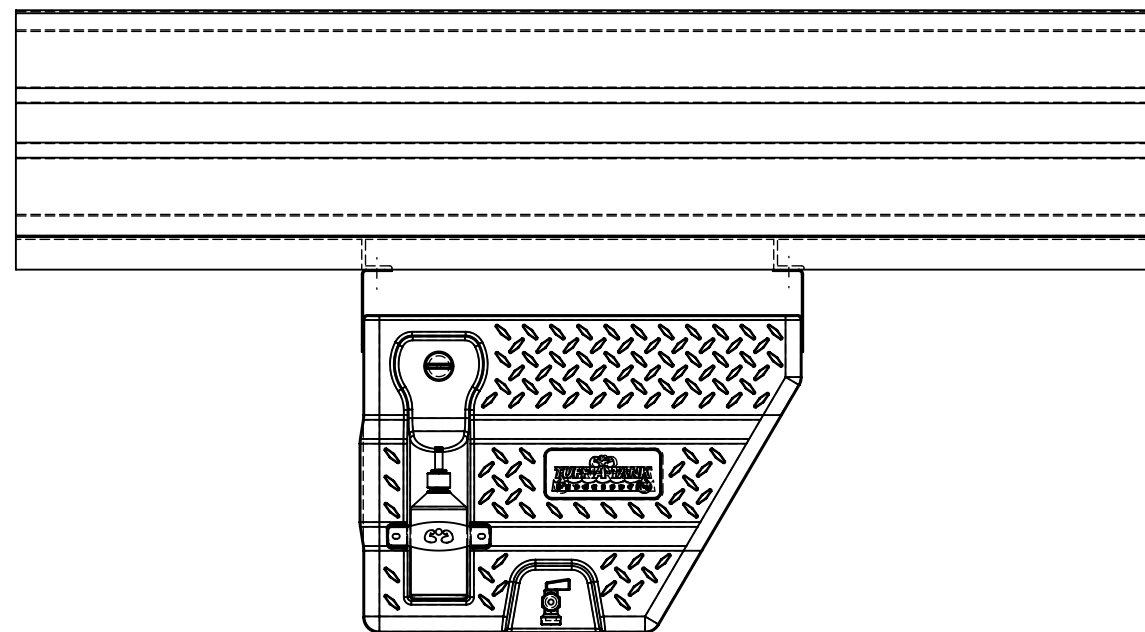

No.	DATE	BY	REVISION DESCRIPTION	APPROV.
A		DH	DESCRIPTION	



Gough Industries Pty. Ltd.  
833 Ingham Road  
Bohle, Townsville  
P.O. Box 7570, Garbutt BC, Qld. 4814.  
Telephone 07 47747606  
Facsimile 07 47747608  
A.C.N. 010 028 547

DRAWN	Signature D.HOLLIER	Date 24.07.12
DRN. CHK		
APPROVED		
		A3

<b>25L UNDERBODY INSTALL INSTRUCTIONS</b>		SCALE	A	REV
S:\Products\Domestic\Underbodies\25L Underbody Handwash Tank\Installation instructions\				