

**INLET PIPE 100mm DWV
C/WFERNCO COUPLING**

DO NOT SCALE

DIMENSIONS MAY VARY BY PLUS OR MINUS 2.5%
DUE TO THE ROTATIONAL MOULDING PROCESS

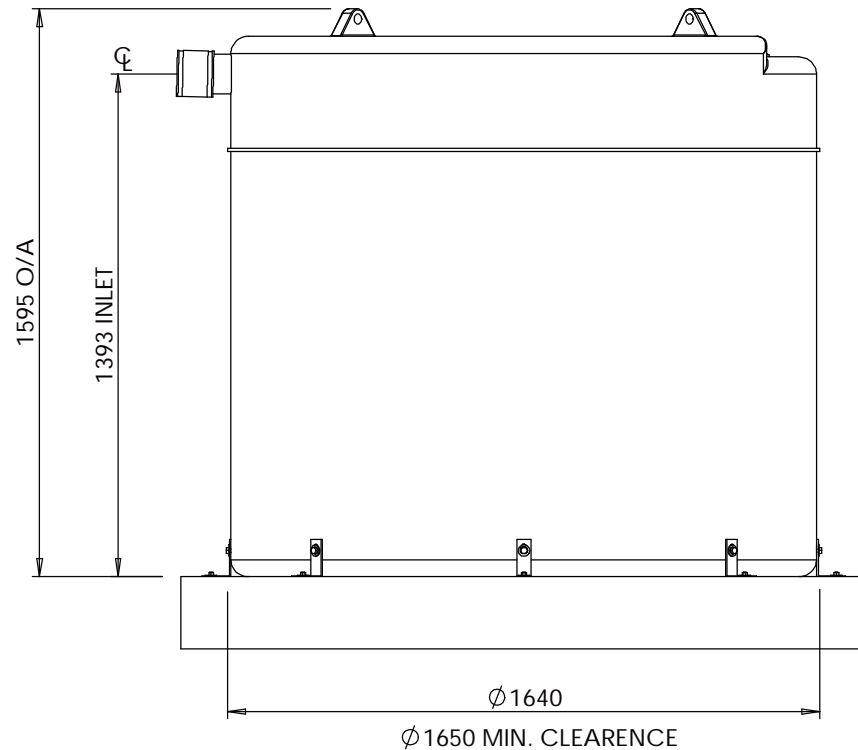

FRONT VIEW

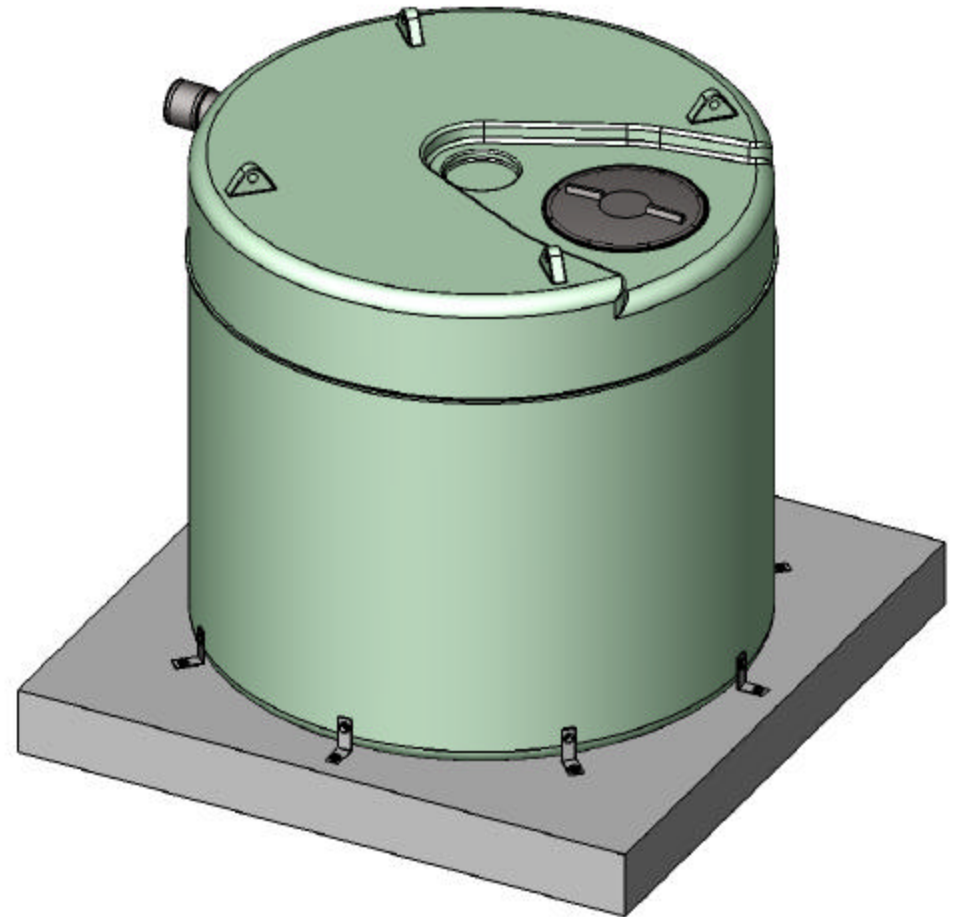

TRIMETRIC VIEW

| No. | DATE | BY | DESCRIPTION | GOUGH |
|-----|------|----|-------------|---------|
| | | | REVISION | APPROV. |



Gough Industries Pty. Ltd.
833 Ingham Road
Bohle, Townsville
P.O. Box 7570, Garbutt BC, Qld. 4814
Telephone 07 47747606
Facsimile 07 47747608
A.C.N. 010 028 547

This drawing remains the property of Gough Industries Pty. Ltd. It is subject to Gough Industries Pty. Ltd.'s recall and must not be reproduced in part or whole or its contents divulged to third parties without prior written approval from Gough Industries Pty Limited.

| Signature | Date |
|---------------|----------|
| S.NAGY | 31.01.04 |
| DRN. CHK | |
| ENGINEER | |
| ENG. CHK | |
| Eng. APPROVAL | |

| | | | |
|-----------------------|---|--|-----|
| 2500 LTR HOLDING TANK | | Gough Plastics Dwg. No. HTSGP0045-01 | REV |
| COMPONENT DETAILS | | | |
| SCALE | 1:20 | A4 | |
| CAD FILE: | H:\HYBRID TOILET SYSTEM\H.T.S Components\ | | |