

FOOD GRADE POLYETHYLENE

PLEASE NOTE DIMENSIONS MAY VARY BY PLUS OR MINUS 3% DUE TO THE ROTATIONAL MOULDING PROCESS

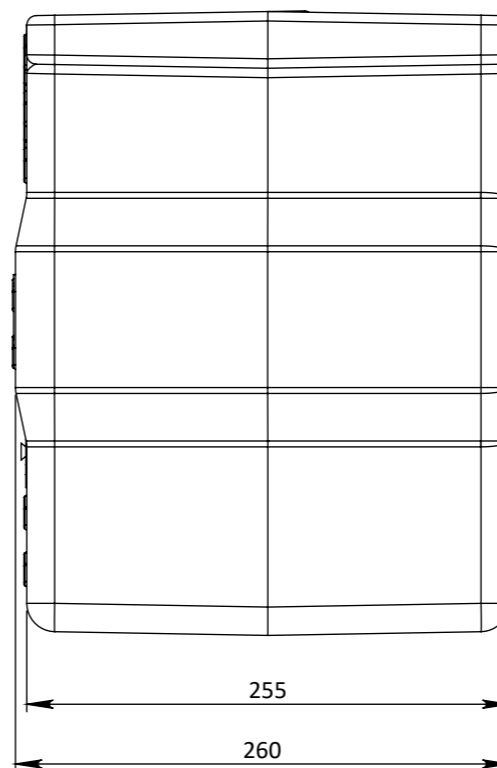
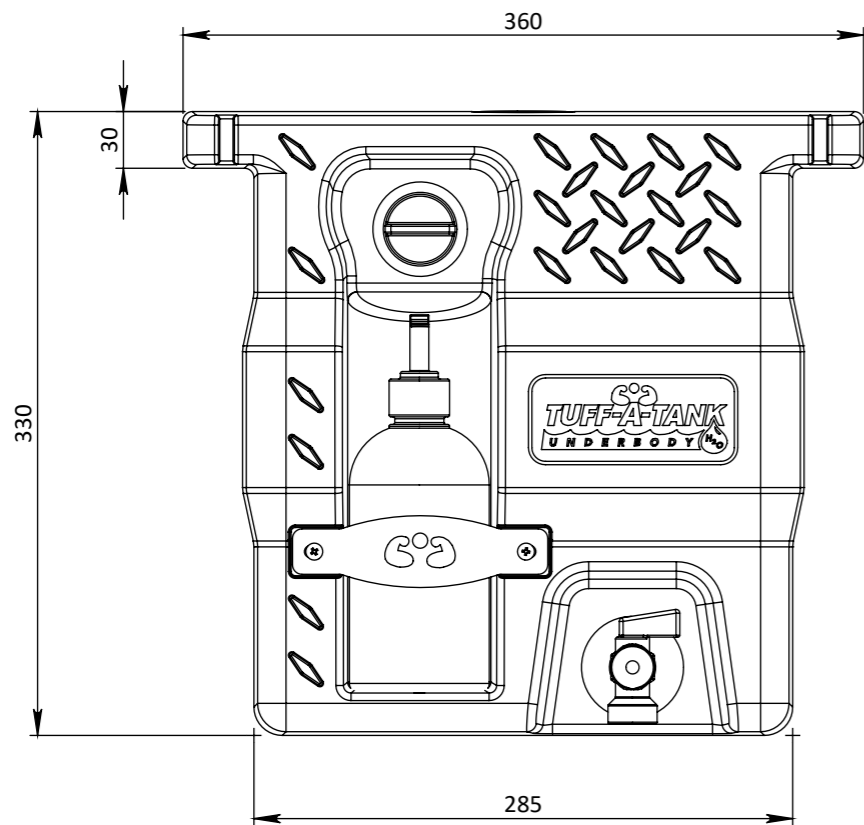
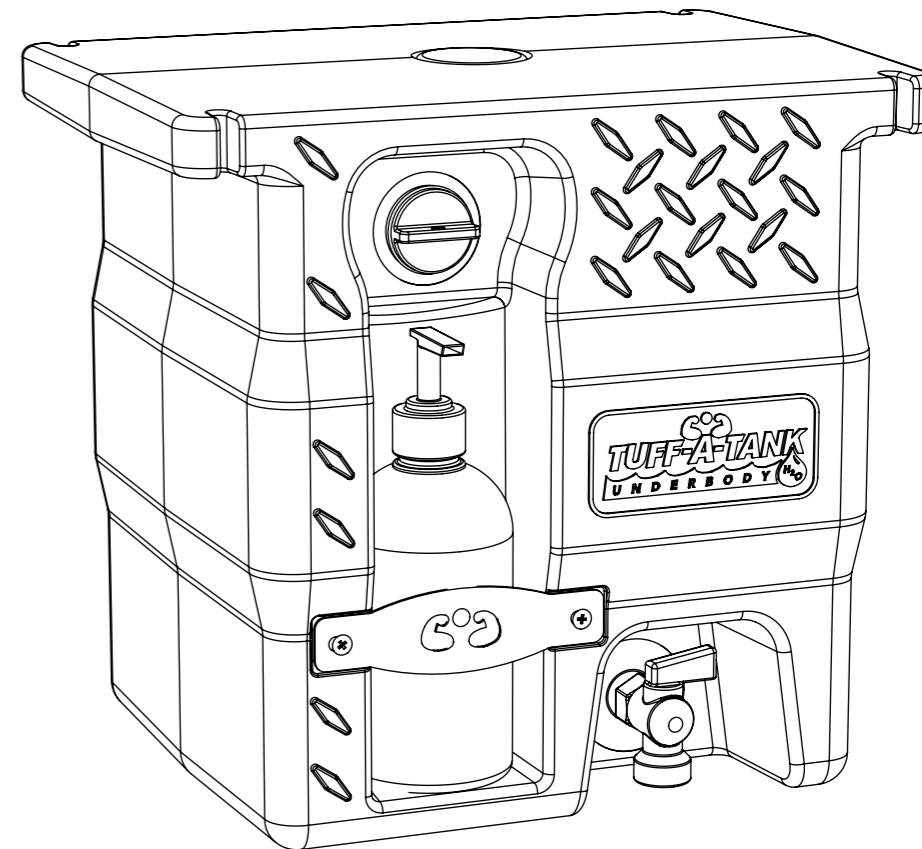
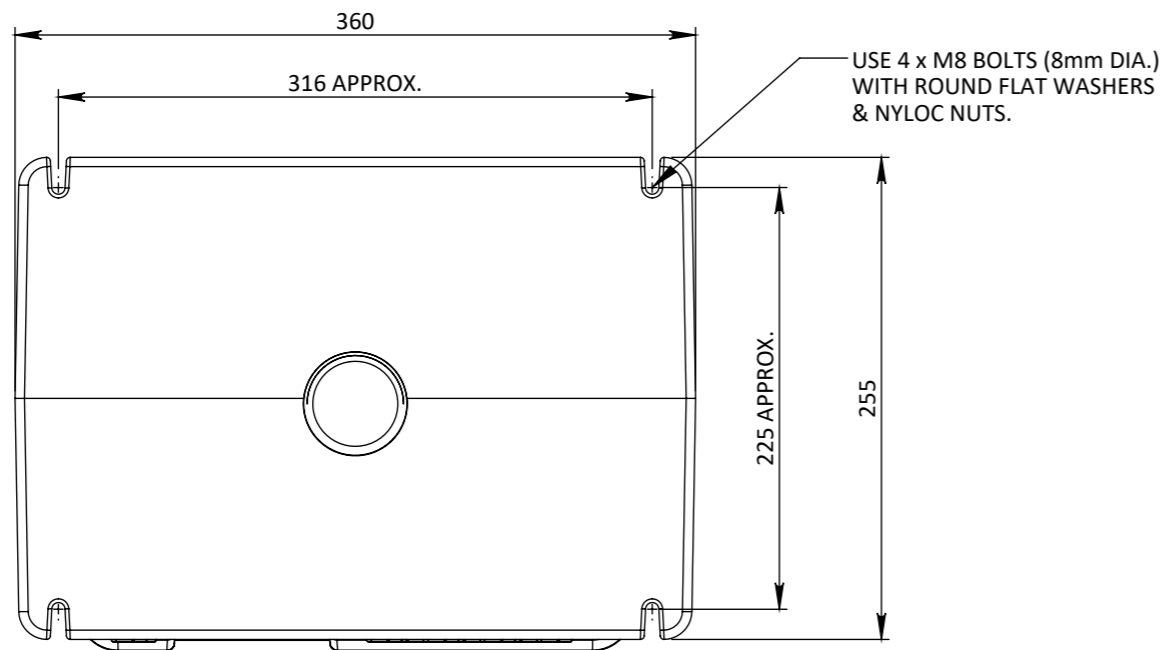

NOTES:

PRODUCT DRAWING

REV	DATE	REVISION DESCRIPTION	DRAWN	CHKD	LEAD ENG
A	12.06.17	PRODUCT DRAWING	DH	BR	



A.C.N. 010 028 547
 Gough Industries Pty. Ltd.
 833 Ingham Road
 Bohle, Townsville
 P.O. Box 7570, Garbutt BC, Qld. 4814.
 Telephone 07 47747606
 Facsimile 07 47747608

CLIENT LOGO.

15L UNDERBODY HANDWASH TANK

SCALE

Gough Plastics Drg. No.
FBOX401.1501

A

REV