

1,500 L WATER CARTAGE TANK STANDARD SKID

FFAR500.1500 + FFAR500.4015.1

TOLERANCES
UNLESS NOTED OTHERWISE
PLEASE ALLOW BELOW TOLERANCES
DIMENSIONS <200mm - ALLOW ±5mm
DIMENSIONS 200 - 1000mm - ALLOW ± 10mm
DIMENSIONS >1000mm - ALLOW ± 20mm

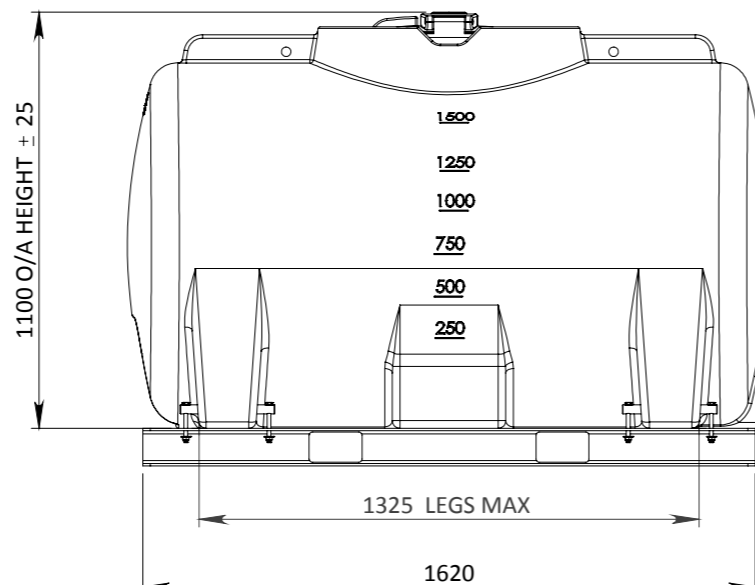
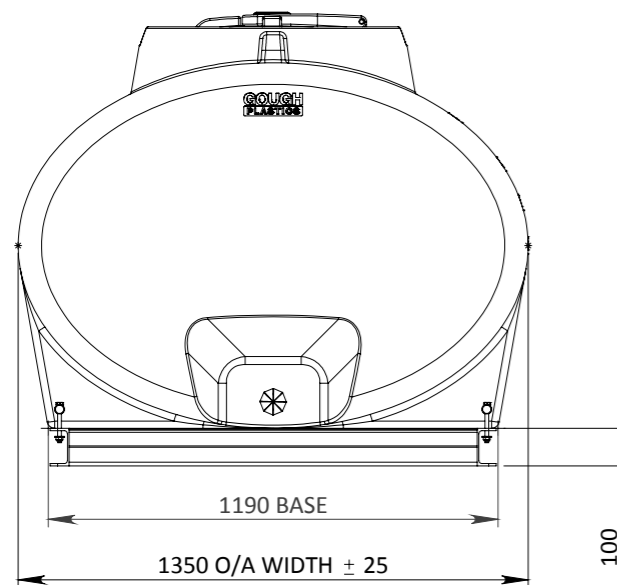
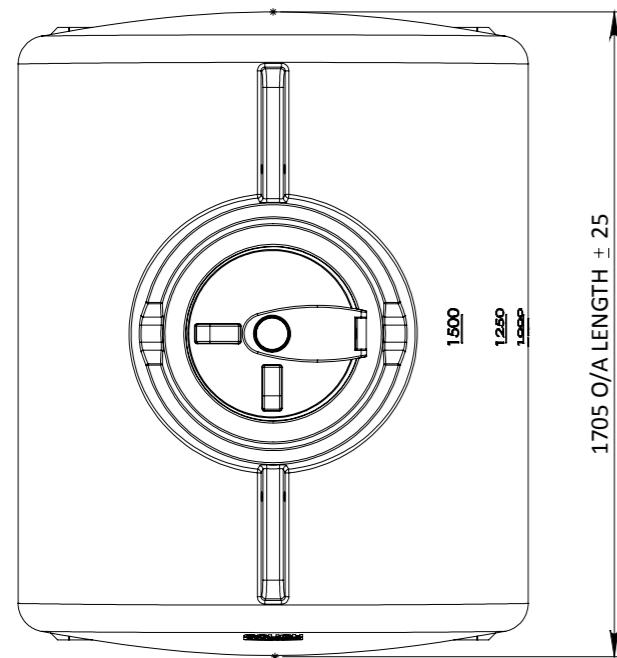

COLOUR: BLUE

TIE DOWN / LIFTING POINTS
WARNING: LIFT EMPTY ONLY

1500 L STANDARD SKID
GALVANISED STEEL

455 mm HINGED LID - VENTED

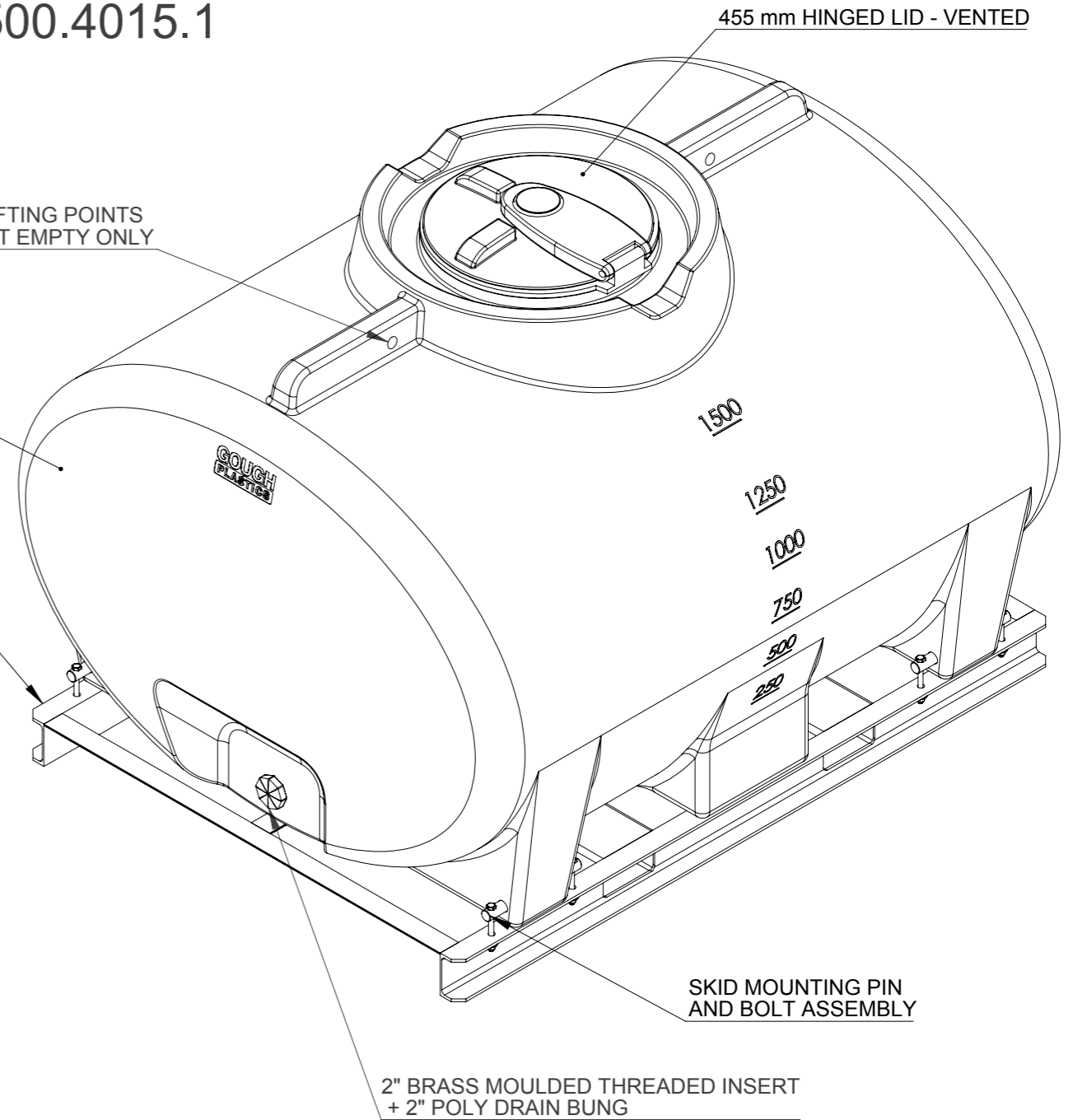

TANK DRY WEIGHT : 65 KG APPROX
SKID WEIGHT : 70 KG APPROX

0	19.03.20	SALES DRAWING	MC	DH		<p>A.C.N. 010 028 547 Gough Industries Pty. Ltd. 833 Ingham Road Bohle, Townsville P.O. Box 7570, Garbutt BC, Qld. 4814. Telephone 07 47747606 www.gough.com.au</p>	CLIENT LOGO.	1,500L CARTAGE TANK				
							SCALE	NTS	A3	GOUGH PLASTICS DRAWING No.	RUR-WATER-1500-S	REVISION
												0
								SOLDWORKS:	S:\Solidworks\Rural\Cartage Tanks\1500 L\Water			
REV	DATE	REVISION DESCRIPTION	DRAWN	CHKD.	ENG.	Dimensions are in millimetres (mm) unless noted.	PDF. FILE PATH:	S:\Products\Marketing Rural\Cartage Tanks\1500 L Cartage				