

1,500 L MOLASSES HD CARTAGE TANK WITH SKID

FFAR500.1502 + FFAR500.4015.1

TOLERANCES
UNLESS NOTED OTHERWISE
PLEASE ALLOW BELOW TOLERANCES
DIMENSIONS <200mm - ALLOW ±5mm
DIMENSIONS 200 - 1000mm - ALLOW ± 10mm
DIMENSIONS >1000mm - ALLOW ± 20mm

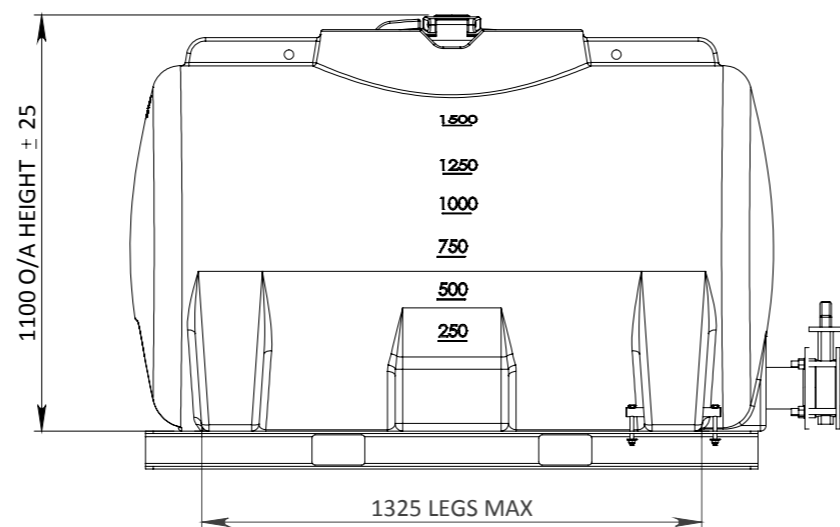
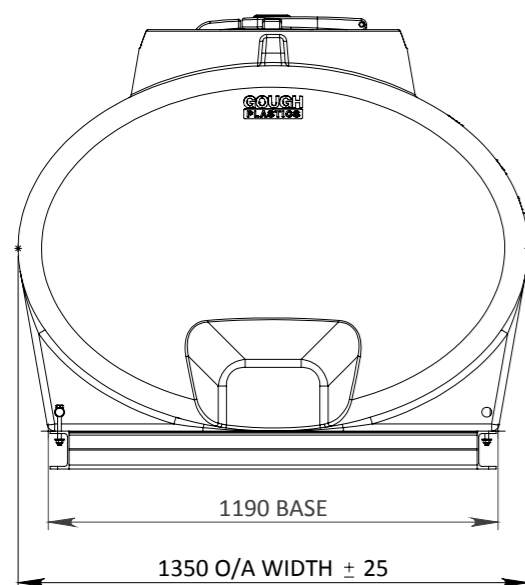
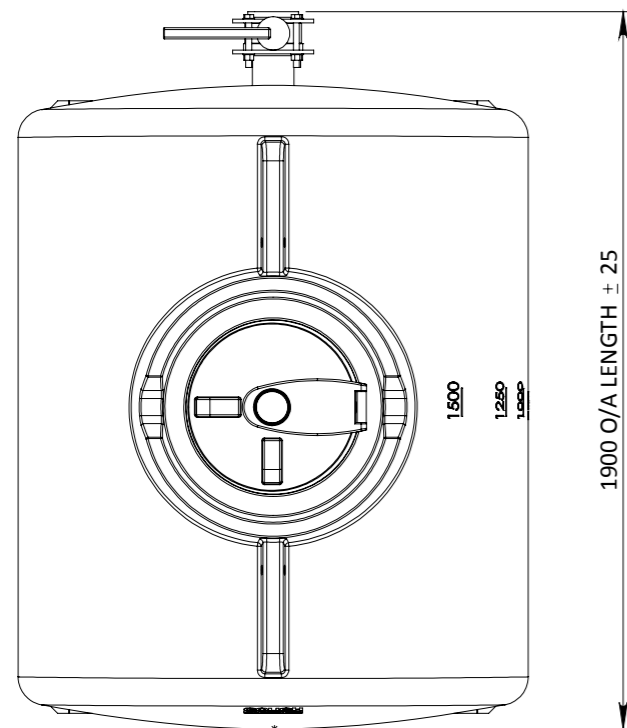

1500 L SKID
GALVANISED STEEL

455 mm HINGED LID - VENTED

TIE DOWN / LIFTING POINTS
WARNING: LIFT EMPTY ONLY

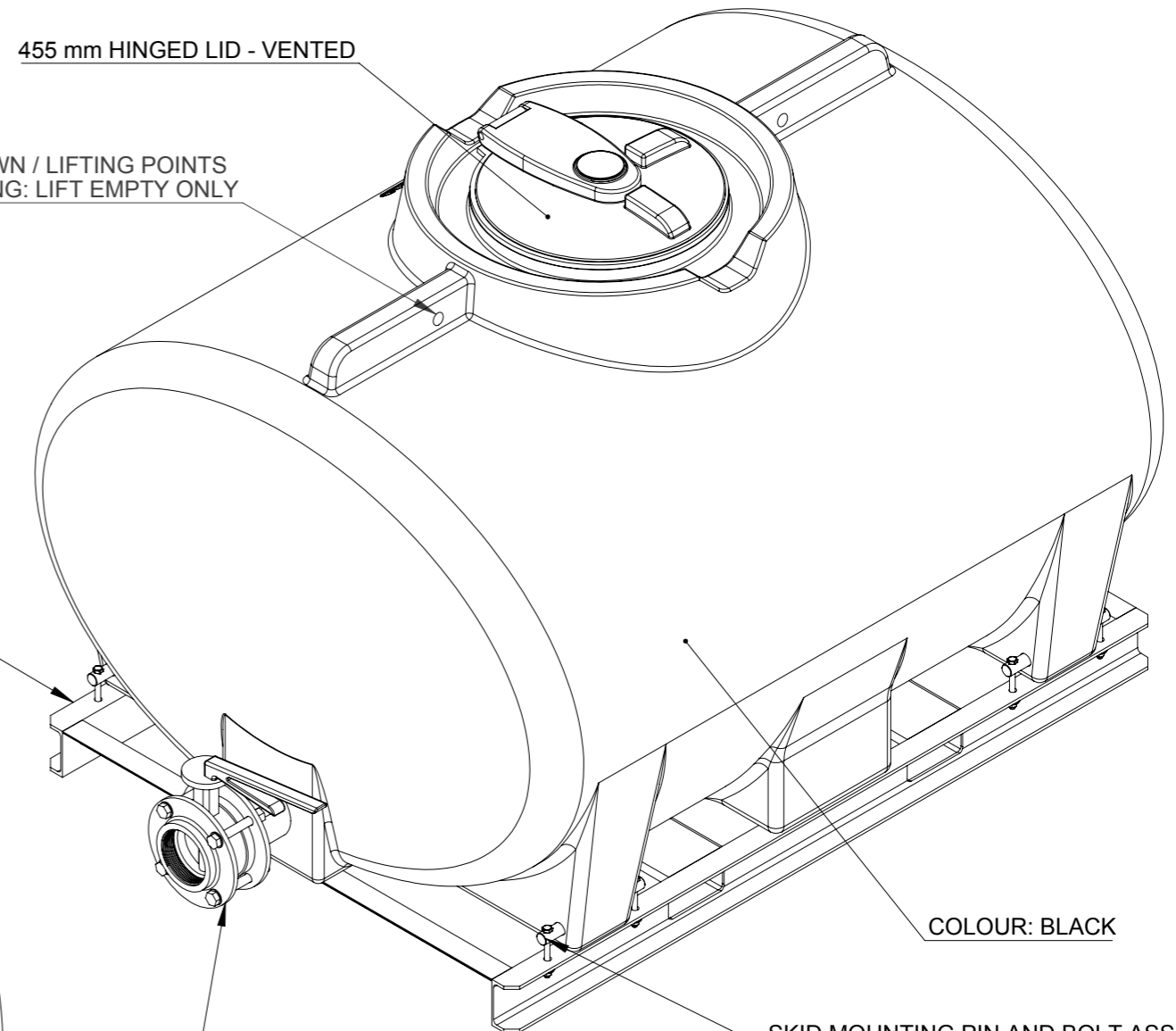

COLOUR: BLACK

SKID MOUNTING PIN AND BOLT ASSEMBLY

4"/100mm STUB FLANGE & VALVE KIT - FTAN204.0030	
4" PE STUB FLANGE	PARWEF0301
4" GAL BACKING RING	PARWEF0401
4" BUTTERFLY VALVE	PARTAC1091
4" GAL DRD FLANGE	PARTTAC1086
M16 x 110mm GAL BOLT (4) + NUT+2FW	PARMIM0040

TANK DRY WEIGHT : 65 KG APPROX
SKID WEIGHT : 70 KG APPROX

REV	DATE	REVISION DESCRIPTION	DRAWN	CHKD.	ENG.
0	18.03.20	SALES DRAWING	MC	DH	