

1,500 L DIESEL CARTAGE TANK

WITH PUMP KIT

FFAR500.1501

TOLERANCES
 UNLESS NOTED OTHERWISE
 PLEASE ALLOW BELOW TOLERANCES
 DIMENSIONS <200mm - ALLOW ±5mm
 DIMENSIONS 200 - 1000mm - ALLOW ± 10mm
 DIMENSIONS >1000mm - ALLOW ± 20mm

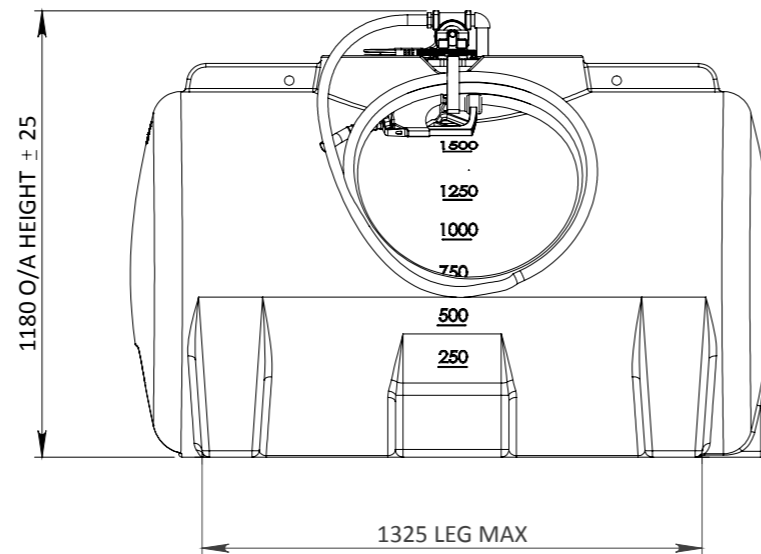
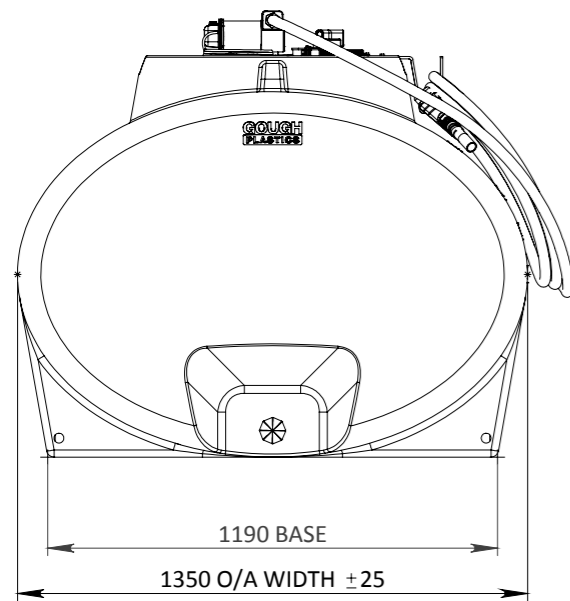
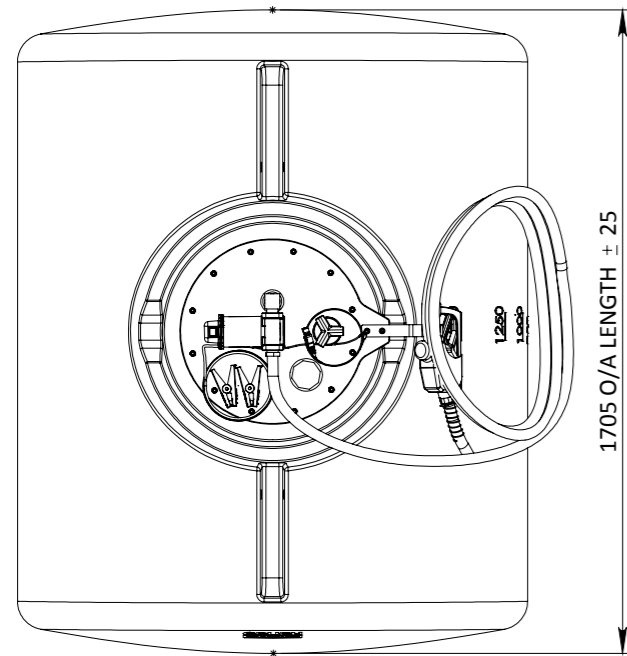

DIESEL MANHOLE WITH PUMP KIT

TIE DOWN / LIFTING POINTS
 WARNING: LIFT EMPTY ONLY

COLOUR: GREY

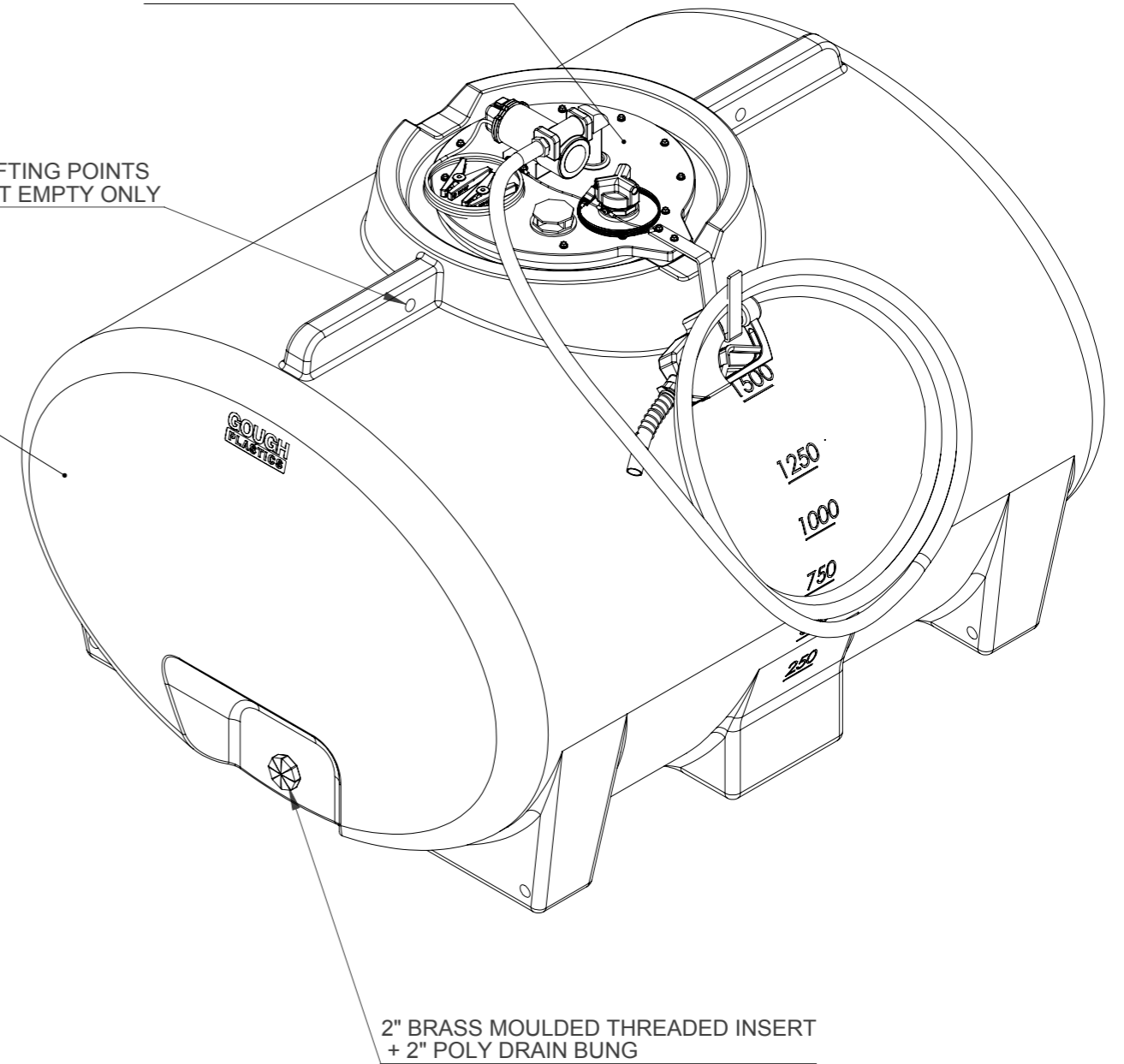

DRY WEIGHT : 70 KG APPROX

0	20.03.20	SALES DRAWING	MC	DH	
REV	DATE	REVISION DESCRIPTION	DRAWN	CHKD.	ENG.



A.C.N. 010 028 547
 Gough Industries Pty. Ltd.
 833 Ingham Road
 Bohle, Townsville
 P.O. Box 7570, Garbutt BC, Qld. 4814.
 Telephone 07 47747606
 www.gough.com.au

Dimensions are in millimetres (mm) unless noted.

CLIENT LOGO.	1,500L CARTAGE TANK		REVISION
	SCALE NTS A3	GOUGH PLASTICS DRAWING No. RUR-DIESEL-1500-P	0
SOLDWORKS:	S:\Solidworks\Rural\Cartage Tanks\1500 L\Diesel		
PDF. FILE PATH:	S:\Products\Marketing Rural\Cartage Tanks\1500 L Cartage		