

1,500 L DIESEL CARTAGE TANK

WITH PUMP KIT AND SKID

FFAR500.1501 + FFAR500.4015.1

TOLERANCES
 UNLESS NOTED OTHERWISE
 PLEASE ALLOW BELOW TOLERANCES
 DIMENSIONS <200mm - ALLOW ±5mm
 DIMENSIONS 200 - 1000mm - ALLOW ± 10mm
 DIMENSIONS >1000mm - ALLOW ± 20mm

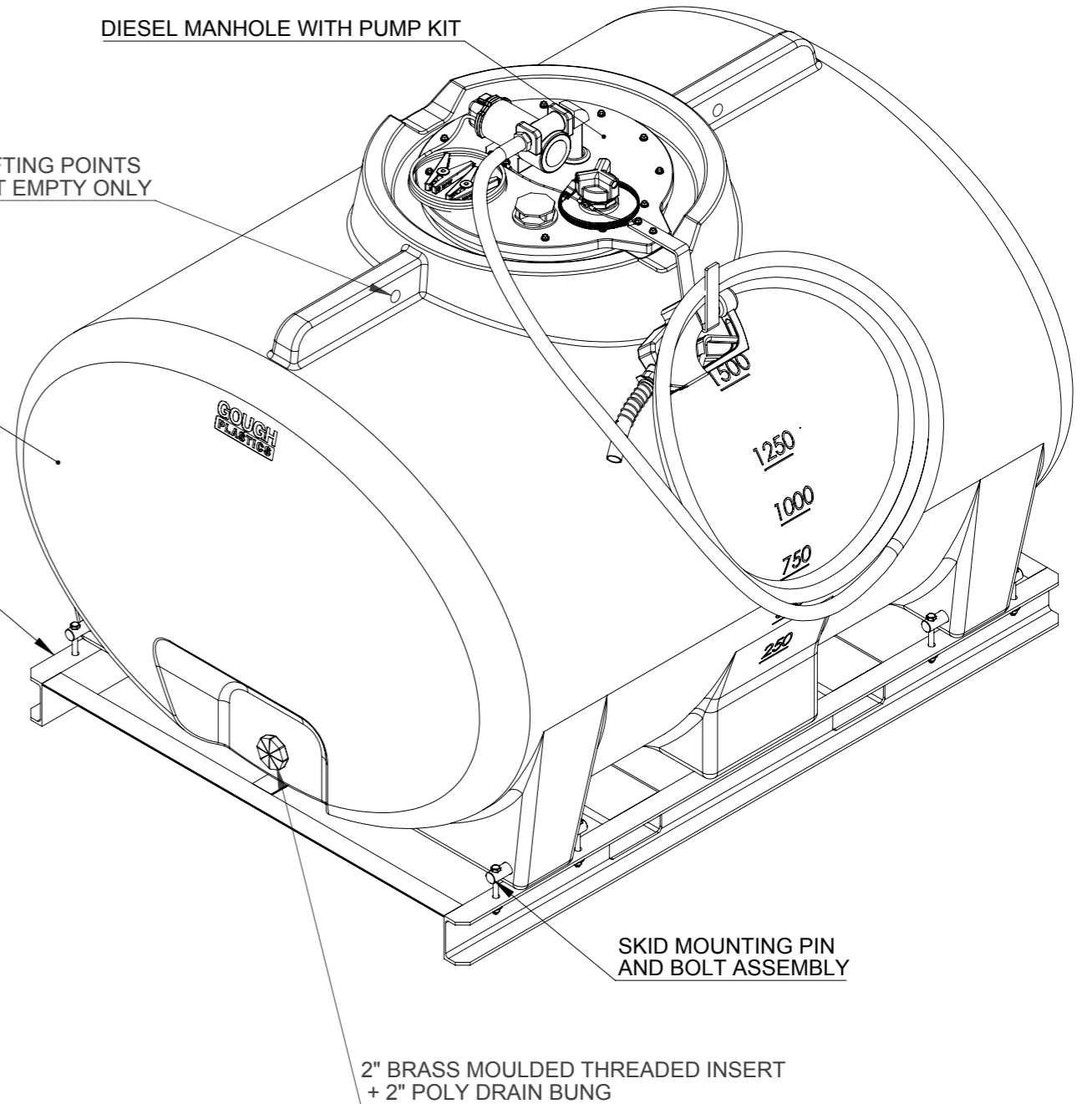
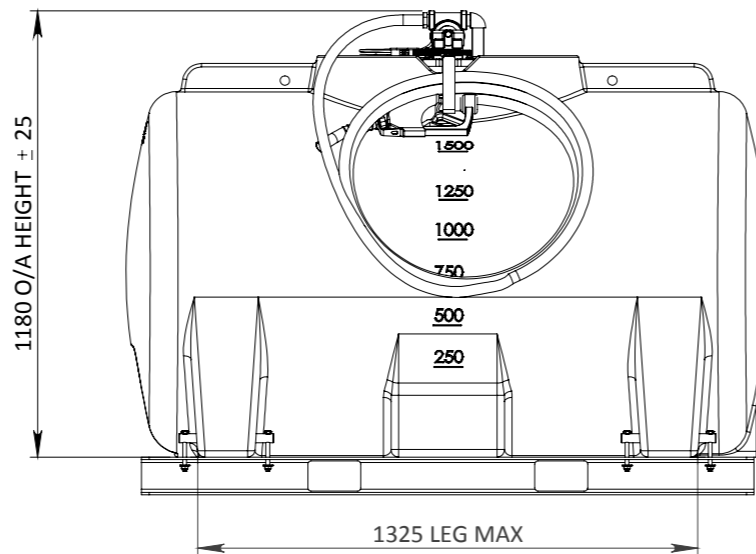
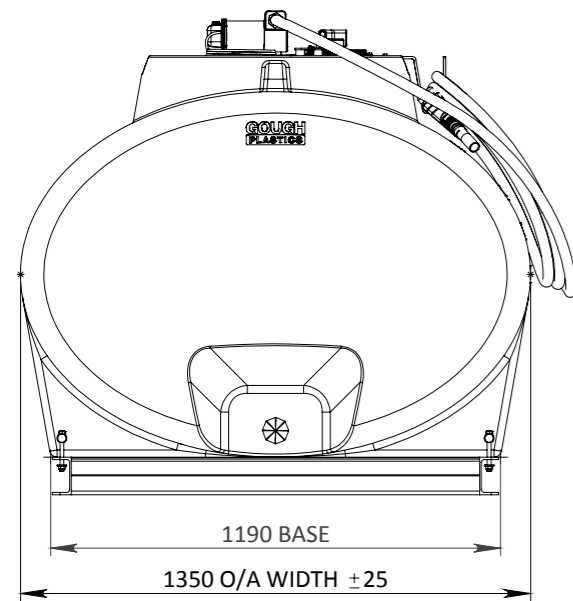
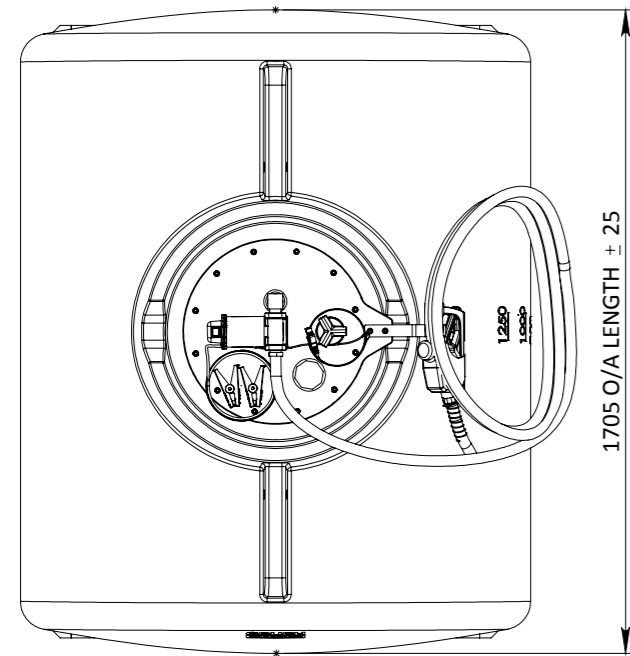

TANK DRY WEIGHT : 70 KG APPROX
SKID WEIGHT : 70 KG APPROX

| | | | | | |
|-----|----------|----------------------|-------|-------|------|
| 0 | 20.03.20 | SALES DRAWING | MC | DH | |
| REV | DATE | REVISION DESCRIPTION | DRAWN | CHKD. | ENG. |



A.C.N. 010 028 547
 Gough Industries Pty. Ltd.
 833 Ingham Road
 Bohle, Townsville
 P.O. Box 7570, Garbutt BC, Qld. 4814.
 Telephone 07 47747606
 www.gough.com.au

Dimensions are in millimetres (mm) unless noted.

| | | | |
|--|----------------------------|---------------------------|----------|
| CLIENT LOGO. | 1,500L CARTAGE TANK | | REVISION |
| SCALE | GOUGH PLASTICS DRAWING No. | | |
| NTS | A3 | RUR-DIESEL-1500-PS | 0 |
| SOLDWORKS: S:\Solidworks\Rural\Cartage Tanks\1500 L\Diesel | | | |
| PDF. FILE PATH: S:\Products\Marketing Rural\Cartage Tanks\1500 L Cartage | | | |